



FB4021

16 GHz BANDPASS FILTER



DESCRIPTION

FB4021 is a 13.9-18.1GHz low-loss microwave bandpass filter. The unit is used in front-end RF and typically EW applications as preselector filtering.

The filter enclosure is silver-plated machined aluminum with SMA female connectors on input and output.

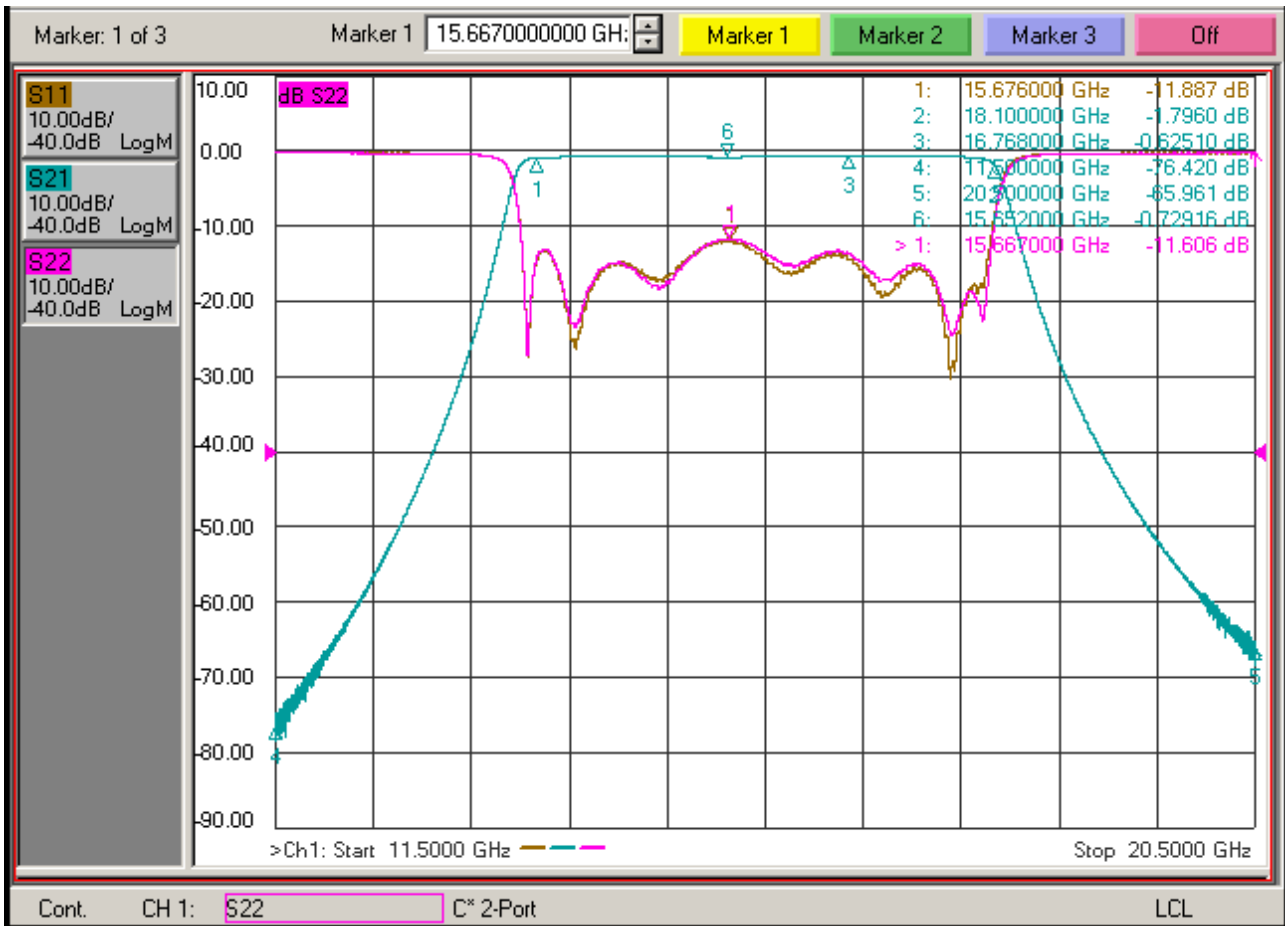

SPECIFICATIONS

Parameter	Limits
Center Freq	16000 MHz
3dB BW [min]	4200 MHz
Passband IL [max]	0.6dBa
VSWR [max]	1.7:1
Passband RL [min]	11.7 dB
Out of Band Rejection	62 dBc @ 11500 MHz 58 dBc @ 20500 MHz
Dimensions	1.5 x 0.5 x 0.5 in (38.10 x 12.70 x 12.70 mm)
Operational Temp Range	-40 °C / +85 °C
Storage Temp Range	-40 °C / +85 °C
RF Connectors	SMA (Female)

MECHANICAL

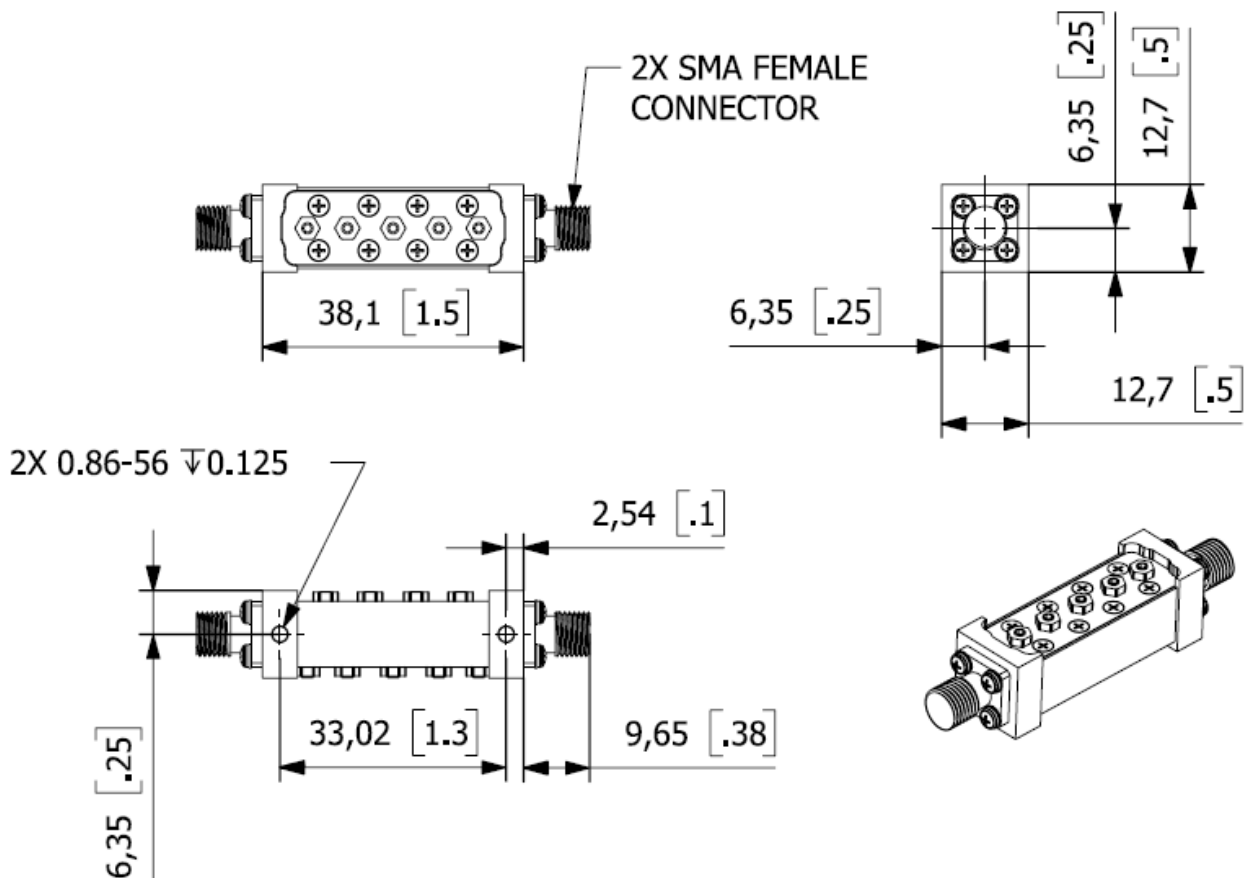

Designed and Manufactured in TÜRKİYE

ASARTECH ARGE TASARIM MÜHENDİSLİK

Sanayi Mahallesi, Teknopark Bulvarı, Teknopark İstanbul 1/1A Blok Zemin Kat No:215-216-217, 34906 Pendik, İSTANBUL/TURKİYE
Phone: 0(216) 514 57 97 Fax:0 (216) 514 57 97

Üniversiteler Mahallesi, 1596. Cadde Hacettepe Teknokent 4. ARGE Binası 95A Kat:3 No:50, 06800 Beytepe Çankaya
ANKARA/TÜRKİYE Phone: 0(312) 227 00 37

www.asartech.com.tr
info@asartech.com.tr

IMPORTANT

- Specifications subject to change without further notice.
- Data given in this document provides its typical performance. Actual device performance is guaranteed by specifications called out by “customer-specific” part number and the associated acceptance test procedure.